



**CAUTION: CAREFULLY READ INSTRUCTIONS BEFORE PROCEEDING. NOT LEGAL FOR SALE OR USE IN CALIFORNIA OR ON ANY POLLUTION CONTROLLED VEHICLES.**

### OVERVIEW

Twin Tuner P/N 16104 is for 2008-2013 H-D® touring models with the 73 pin Delphi® module and electronic throttle control. You can easily adjust your fuel injection to match the requirements of performance parts including camshafts, free flowing exhausts, and low restriction air filters. You can add or subtract fuel.

Installation takes only 10-15 minutes and is very easy, with no splicing, cutting, crimping, or bulky interconnections. All access is at the Delphi ECM. Just remove four wires from the ECM connector, insert these wires into our small mating connectors, insert four new wires from the Twin Tuner into the ECM connector, and connect one ground wire. The unit is completely encapsulated and impervious to moisture. With a very low profile of only ½" and occupying a fraction of the space required by competitive products, you won't have a problem finding a place to mount the unit.

Figure 1 – Twin Tuner



You can use the mode and up/down pushbutton switches to make fuel trim adjustments in the RPM and throttle position ranges required by most applications. The fuel trim value is displayed on a bright daylight readable LED display. The Twin Tuner also has an advanced mode, where you can use the optional USB interface and PC Link Tuner software to make precise fuel adjustments. You can make independent adjustments to the front and rear cylinders.

The Twin Tuner works great in combination with our Twin Scan II Plus tuning aid. You can directly export calculated fuel correction data to Twin Tuner data files. The system can be used for tuning on a dyno or under actual riding conditions on a closed course or race track.

### INSTALLATION

1. If the motorcycle is equipped with a security system (TSSM module), make sure the system is disarmed. **Turn off the ignition switch and disconnect the battery ground cable before proceeding.**
2. Find the Delphi® engine control module (ECM). The ECM is usually located under the seat.
3. Unplug the ECM connector. Cut the cable tie that secures the wire conduit. Use a small flat screwdriver to depress the tabs on the side of the connector and remove the cable cover.
4. Use a small flat screwdriver to gently slide out the green terminal retainer as shown in Figure 2.
5. Refer to Table 1 for connection details. Remove four wires from the ECM connector. Terminal numbers are marked on the back side of the ECM connector. Original equipment wire color codes may vary. Note the color of each wire that you remove. We suggest that you mark up Table 1 with any corrections for future reference.
6. To release terminals, use the supplied plastic push pin as a terminal removal tool. Insert the push pin into the round hole between terminal cavities as shown in Figure 3. This will release the two adjacent terminals. Remove the appropriate terminal. Make sure that the adjacent terminal is not dislodged.
7. Refer to Table 1 and install the four wires from the Twin Tuner into the ECM connector.
8. Use a small side cutter to make a slit in the cable conduit so that the four wires you removed can exit. Wrap electrical tape around the cable conduit. Reassemble the ECM connector. If the green retainer will not slide back into position, check for dislodged terminals and push them back

up. Secure the cable conduit with a supplied cable tie.

9. Refer to Figures 4-6. Use the supplied terminal insertion tool to insert the four terminals removed from the ECM connector into the two supplied soft rubber mini Sure-Seal connectors. To ease terminal insertion, first insert the tool into each connector cavity and rotate the tool several times to remove any rough spots. Lubricate the connectors and terminals with isopropyl alcohol (rubbing alcohol available at any pharmacy). **Do not use other lubricants such as WD-40 as these will make the connector too slippery and you will not be able to hold it securely during the insertion process.** Start by pushing a terminal into the connector by hand. Then use the insertion tool to push on the end of the terminal while slightly rotating the tool back and forth. Make sure each terminal is pushed in so that it is flush with the end of the connector as shown in Figure 6. If you push a terminal in too far or need to remove it, gently pull out on the wire.
10. Mate the mini Sure-Seal connectors together and verify that the wire colors are correctly oriented as shown in Figure 4.

Figure 3 – ECM Connector Terminal Removal

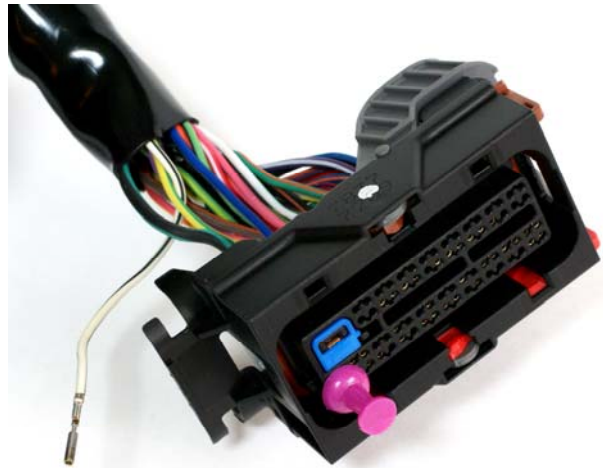

Figure 2 – ECM Connector Retainer Removal and Terminal Numbering Detail

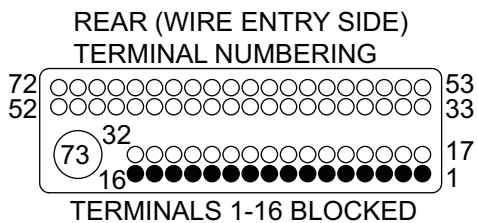

Figure 4 – Twin Tuner Wiring

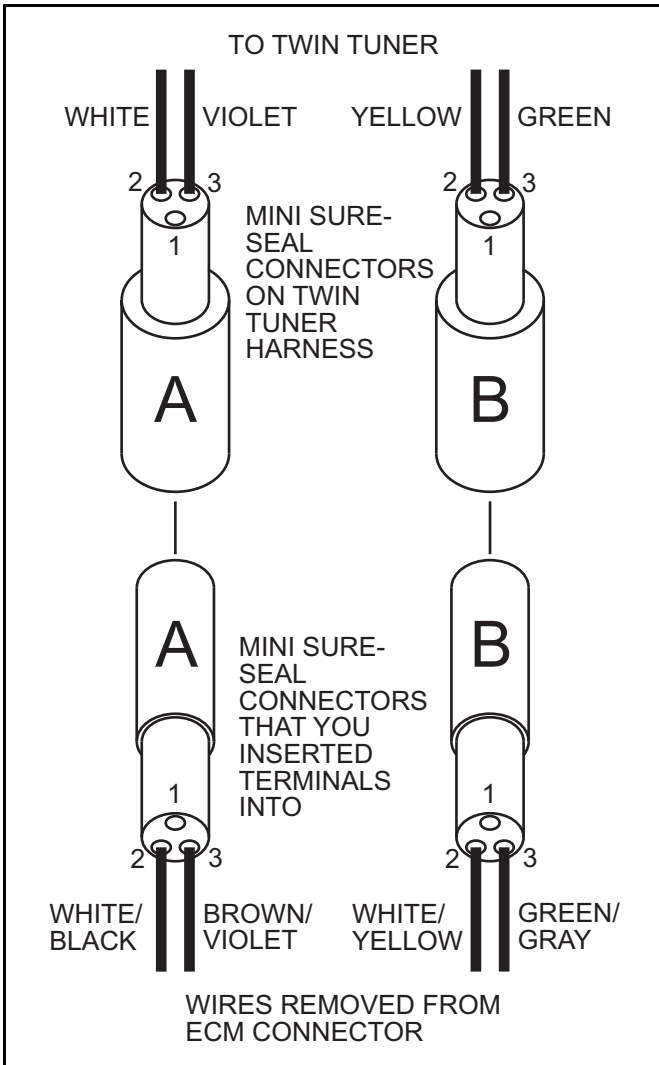

Figure 5 – Terminal Insertion

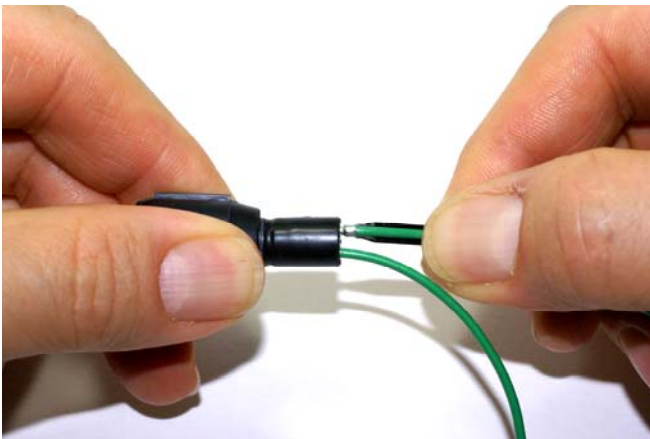

Figure 6 – Terminal Insertion Detail



Figure 7 – Completed Wiring at ECM

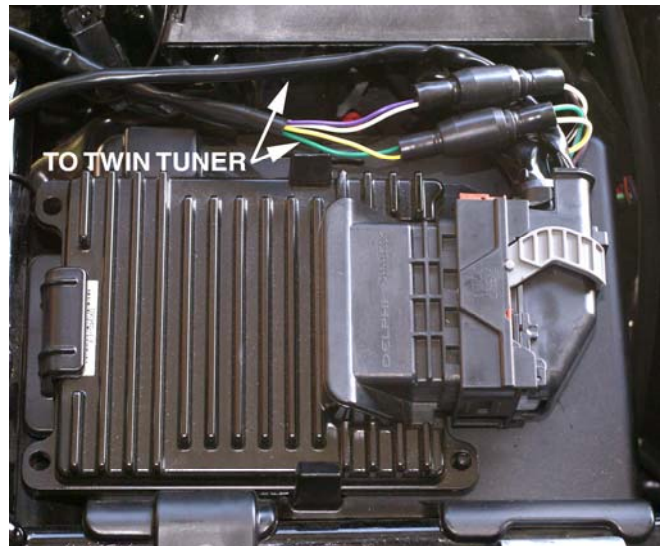

Figure 8 – Completed Twin Tuner Installation



- 
11. Connect the Twin Tuner black ground wire to an appropriate ground. You can generally find one or more screws used for other ground connections under the seat or near the ECM.
  12. The Twin Tuner brown wire with Weather Pack connector is the data link used for PC communications. If not used, tape up this wire.
  13. Refer to Figure 8 for suggested Twin Tuner mounting location. You can use Velcro material to secure the unit.

14. Reconnect the battery ground cable. Do not attempt to start the engine until you have completed the initial setup.

***CAUTION: Professional installation is recommended. The female Delphi Micro64 terminals are delicate and easily damaged. Replacement terminals are available as P/N 829-15356827 from Mouser Electronics (1-800-346-6873 or [www.mouser.com](http://www.mouser.com)). The required Delphi crimping tool is P/N 15397700 available from Power & Signal Group (1-800-722-5273 or [www.powerandsignal.com](http://www.powerandsignal.com)). A professional insertion tool for the mini Sure-Seal connectors is also available as P/N MSS-T-Tool from PEI Genesis (1-888-349-9787 or [www.pei-genesis.com](http://www.pei-genesis.com)).***

Table 1 – Wiring Hookup

<b>Twin Tuner Wires</b>		
<b>Wire Color</b>	<b>To ECM Connector</b>	<b>Signal</b>
Red	23	Rear Injector
Orange	28	Front Injector
Violet	37	Throttle Position Sensor
White	72	Ignition Switch
<b>ECM Wires (removed from ECM connector)</b>		
<b>Wire Color (ECM terminal)</b>	<b>To Mini Sure-Seal Plug</b>	<b>Signal</b>
White/Black (72)	2A	Ignition Switch
Brown/Violet (37)	3A	Throttle Position Sensor
White/Yellow (28)	2B	Front Injector
Green/Gray (23)	3B	Rear Injector

## **INITIAL SETUP**

The Twin Tuner has a 10 position rotary mode switch used to select fuel trim parameters to edit, two digit LED display, and up/down pushbutton switches to change the parameter value. Fuel trim parameters are listed in Table 2. Note that the rectangular LED to the left of the two digit LED is illuminated for negative values. **Values represent percent fuel trim.** You can use a small flat screwdriver to rotate the mode switch. You can make parameter changes on-the-fly with the engine running.

Before starting the engine for the first time, turn the ignition switch and run/stop switch on. The idle air control motor will move to the starting position and the fuel pump will be energized for several seconds, making an audible buzz. Set the mode switch from each position from 0 to 9. The LED display should be off in position 0. The LED display should illuminate and read 00 in positions 1-9 (unless your Twin Tuner has been preprogrammed for some specific application). If required, use the up/down pushbuttons to set the values for each position to zero. Start the engine and verify normal operation. If the engine will not start, or runs on one cylinder, recheck connections.

## **BASIC TUNING**

Table 2 shows the engine operating ranges affected by fuel trim values in terms of RPM and throttle position sensor (TPS) values. For tuning recommendations and initial setup tables for common applications refer to the Appendix starting on page 11. For more details, please visit our Twin Tuner Tech FAQ at [www.daytona-twintec.com/tech\\_tuner.html](http://www.daytona-twintec.com/tech_tuner.html).

Table 2 – Mode Switch Settings

Parameter	Fuel Trim Operating Range
0	Display off – used to prevent inadvertent changes during normal engine operation
1	Idle 750-1250 RPM 0% TPS
2	Low cruise 1250-2000 RPM 2.5-50% TPS
3	High cruise 2000-3750 RPM 2.5-50% TPS
4	Wide open throttle 1250-2000 RPM 50-100% TPS
5	Wide open throttle 2000-2750 RPM 50-100% TPS
6	Wide open throttle 2750-3750 RPM 50-100% TPS
7	Wide open throttle 3750-4750 RPM 50-100% TPS
8	Wide open throttle above 4750 RPM 50-100% TPS
9	Acceleration enrichment (0 = none, 10 = maximum)

## ADVANCED TUNING

The Twin Tuner also has an advanced mode, where you can use the optional USB interface and Windows software to check and observe system operation (Tuner Log) and make precise fuel adjustments (PC Link Tuner).

## PC REQUIREMENTS

The Twin Tuner connects to your PC by means of an optional USB interface (P/N 18014) that is also used with our other engine controls. The PC must have a free USB port. If you have an older PC without USB capability, you cannot use the advanced tuning capability.

We recommend a laptop PC with Pentium processor and super VGA display (SVGA with 1024 x 768 pixel resolution) running Windows XP/Vista/7. Data display is graphics intensive and a high speed Pentium processor is recommended. Processors slower than 300 MHz will exhibit sluggish program loading and response. The PC must have a CDROM drive for program loading.

PC Link Tuner software includes print commands to print downloaded data. The program has been tested with Hewlett-Packard laser and inkjet printers and Epson inkjet printers. We recommend using a color inkjet printer.

## SOFTWARE INSTALLATION

The software is supplied on CDROM media or in the form of a compressed file downloaded from our website. The installation process uses InstallShield. This industry standard installer is based the new Microsoft Windows Installer service that greatly

reduces potential problems such as version conflicts and allows for application self-repair.

There are two programs to install: Tuner Log and PC Link Tuner. Start by installing Tuner Log. If you are downloading software from the web, only download and install one program at a time. Before proceeding with installation, shutdown any other applications that may be running. For Windows Vista, you must disable the User Account Control (UAC) during installation. If you are not familiar with the UAC, please refer to the Vista UAC Tech Note on our website's Tech FAQ for details.

Use the Windows Explorer or the Run command from the Windows Start Menu to launch setup.exe in the Tuner\_Log folder on the CDROM or the setup.exe file downloaded from our website. InstallShield will install the software in an appropriate folder under Program Files.

Repeat the installation process for PC Link Tuner. Use the Windows Explorer or the Run command from the Windows Start Menu to launch setup.exe in the PC\_Link\_Tuner folder on the CDROM or the setup.exe file downloaded from our website. InstallShield will install the software in an appropriate folder under Program Files.

Once InstallShield has completed the installation, Tuner Log and PC Link Tuner will appear on the Windows Start Menu. You can then launch them just as you would any other Windows program.

PC Link Tuner software requires the Monospace 821 BT fixed pitch printer font in order to properly align columns when printing. The Monospace 821 BT font is included in the distribution media and automatically copied to your Windows Fonts folder during installation. A backup copy is also placed in the program folder. If you accidentally delete this font, use the Install New Font command from the Fonts folder

---

File menu. The filename associated with Monospace 821 BT is monos.ttf.

## **TWIN TUNER CONNECTION**

Follow the instructions supplied with the optional USB interface to install the required USB drivers and configure the COM port. Once you have configured a COM port number for your new USB Interface, make sure that you use this same COM port selection in the Tuner Log and PC Link Tuner software. Use the "TC88A AND ALL OTHERS" switch setting.

An adapter harness is supplied with the USB Interface for use with the Twin Tuner. Connect the alligator clip on the black wire to ground and the Packard Weather Pack connector to the mating connector on the brown wire from the Twin Tuner.

Turn the ignition key and engine run/stop switch on to provide power to the system. Do not start the engine if you want to download or upload data with PC Link Tuner.

## **TUNER LOG SOFTWARE**

When the engine is running, you can display real time engine data on an instrument panel type screen as shown in Figure 9 by using the View Real Time Data command on the View menu.

You can also check proper operation of the throttle position sensor (TPS) when the run/stop switch

is on (engine not running). Rotate the throttle through the full range of motion. The TPS% value should go from zero to 100%.

Real time engine data is displayed on an instrument panel type layout with a round tach gauge and bar graph type gauges for all other parameters. Status messages are displayed in a separate window. If the engine is not running, most values will appear as zero or off.

Displayed parameters include:

**RPM** – engine crankshaft RPM (numeric value displayed beneath gauge)

**TPS** – throttle position (0 to 100%)

**BAT** – battery voltage

**FRONT INJ PW, REAR INJ PW** – injector pulse width in milliseconds (pulse width commanded by ECM before fuel trim by Twin Tuner)

**FRONT FUEL%, REAR FUEL%** – fuel trim in percent (0% means no change)

**STATUS** – engine running status and basic mode (switch settings used to trim fuel) or advanced mode (PC Link Tuner tables used to trim fuel)

Figure 9 – Real Time Engine Data Display

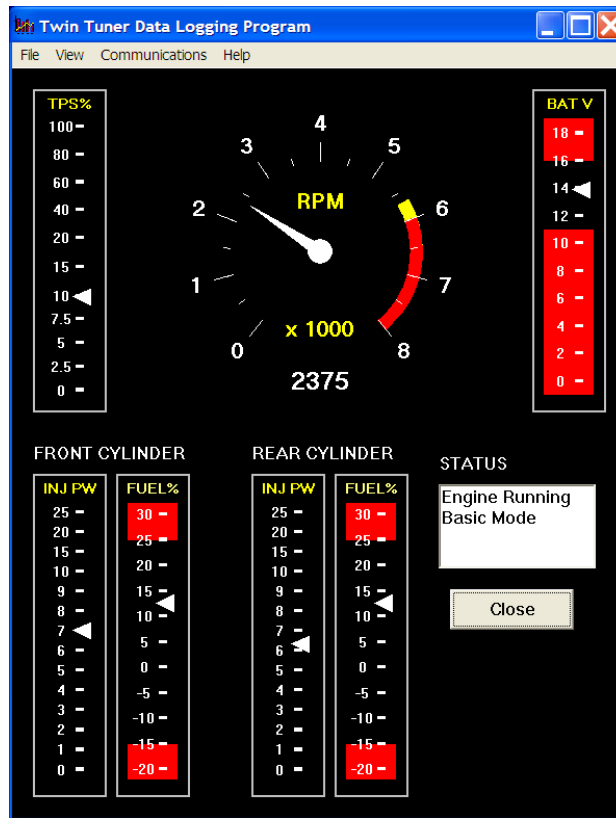

## PC LINK TUNER SOFTWARE

Before the engine is started, you can download or upload data with PC Link Tuner.

After PC Link Tuner is launched, the main screen appears blank. You have two options for obtaining data for editing. You can open a previously saved data file by using the Open File command on the File menu or you can download data from an attached Twin Tuner unit by using the Download Data From Twin Tuner command on the Communications menu. Note that Twin Tuner data files use a .dat extension. You should create a separate folder to store these files.

Once you have Twin Tuner data, you can edit various 3D tables and parameters. 3D fuel trim tables are accompanied by chart displays that help visualize the data. You can also rotate the 3D chart display for a better view of a particular region. You can print the data associated with an active table or Twin Tuner parameters by using the appropriate Print command from the File menu. When you open a file or download data from a Twin Tuner, the data is stored in a buffer memory. After editing a table, you can save the edits to this buffer memory. Once you have completed all your

edits, you can save the data in buffer memory to a file or upload it back to the Twin Tuner by using the appropriate command from the File or Communications menu.

Please note that communication is only possible if the ignition key and run/stop switch are turned on and the engine has not yet been started.

## TWIN TUNER PARAMETERS

Twin Tuner parameters shown in Figure 10 control the overall operating mode of the unit and allow you to preset parameters without using the switches on the unit. Options and parameters that you can set include:

**Twin Tuner Version** – when a file is opened or data is downloaded, the software automatically determines the Twin Tuner version. Do not use EX version files or click on the EX option with the standard (race) Twin Tuner.

**Basic Mode** – fuel trim values are based on switch settings. This is the default operating mode.

**Advanced Mode** – fuel trim values are based on the 3D front and rear cylinder fuel trim tables.



**Injector Swap on Enrichment Mode** – positive fuel trim is applied to the opposite injector to compensate for fuel distribution problems in some applications. This mode is not normally selected. Refer to tech support for additional details.

**Enable Manual Trim in Advanced Mode** – this option is only available in advanced mode and is grayed out in basic mode. If this option is selected, switch settings 1 to 8 can be used to manually trim the 3D fuel tables. If this option is not selected, switch

settings 1 to 8 are ignored (switch setting 9 for acceleration enrichment is still active).

**Parameters 1-9** – display fuel trim parameter values. Can be used to edit or preset values without using the switches on the unit. Fuel trim parameters are listed in Table 2.

**User Data** – you can enter up to 32 characters of user data that will be saved in EEPROM memory. User data can contain comments or serial numbers.

Figure 10 – Twin Tuner Parameters

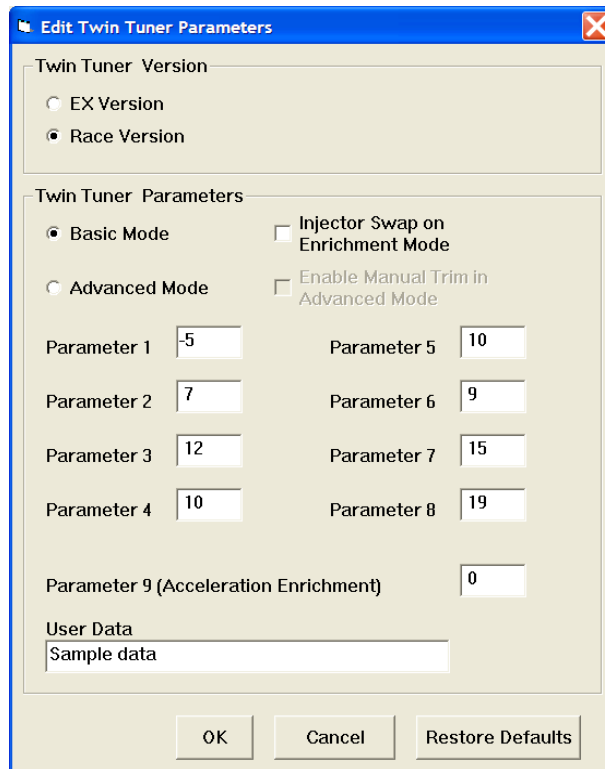

## EDITING 3D TABLE DATA

You can edit the front and rear cylinder fuel trim tables. Before you can edit one of these tables you must either open a data file or download data from a Twin Tuner unit. Numeric data is always edited on the spreadsheet grid. The front and rear cylinder fuel trim tables are accompanied by 3D graphs that help visualize the data.

Each table consists of 18 rows from 500 to 6,500 RPM and 9 throttle position columns from 0% to 100%. The 6,500 RPM value is used at all higher RPM levels.

After you have edited a table, you must use the Save Table Edits To Buffer command from the Edit menu to save your edits to buffer memory. If you use

the Close Table command from the Edit menu, all your edits are lost.

### Front and Rear Cylinder Fuel Trim Tables

The fuel trim values in these tables are only active if advanced mode is selected. You can enter fuel trim values from -20% to +30% in every cell. Unless you have specific experience in trimming individual cylinders and the associated fuel distribution problems, we suggest that you use the same values for both front and rear cylinders. You can edit a table for the front cylinder. After saving the table edits to buffer memory, you can use the Copy Front Cylinder Trim to Rear command from the Edit menu to quickly copy the entire table.

Figure 11 – Typical Front Cylinder Fuel Trim Table

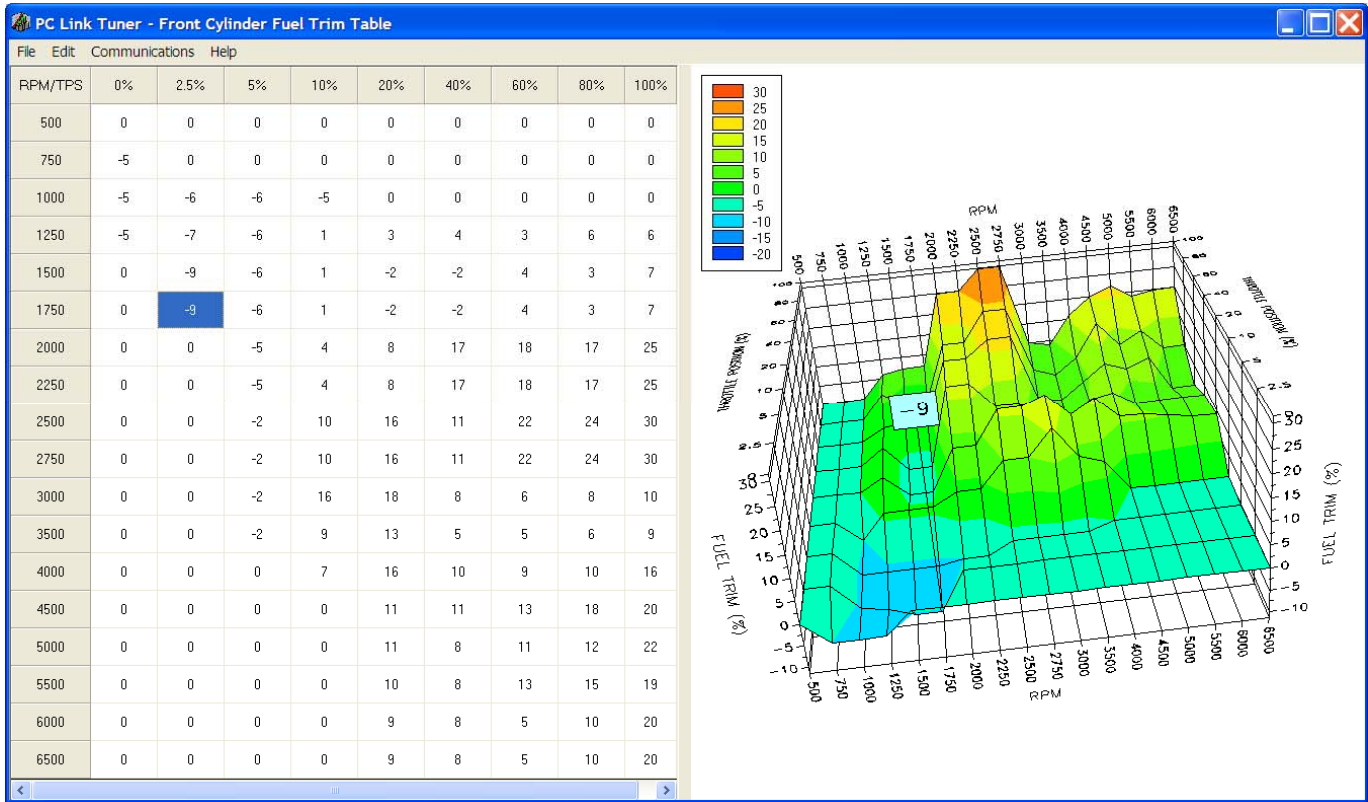

**Editing Table Data**

You can edit table data using standard Windows copy and paste operations by selecting cells and then clicking the right mouse button to pop-up the edit menu. You can select cells by dragging the mouse with left button down. You can also use the Modify command on the pop-up menu. When you enter a value, the presence of optional sign (+ or -) or percent (%) characters affects the outcome of the Modify command as shown in Figure 12.

Figure 12 – Modify Command

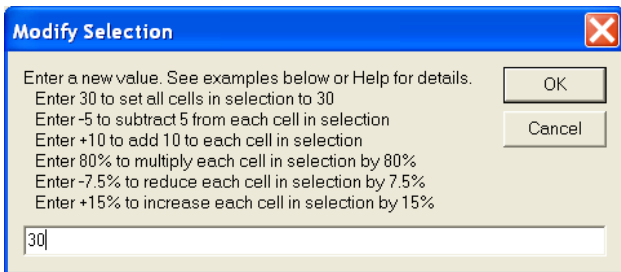

**Data Export and Import by Means of Copy and Paste**

You might want to export or import 3D table data to or from another application such as Microsoft Excel and other programs with tables that support copy and paste operations. You can directly copy and paste data to and from the PC Link Tuner program. In the PC Link Tuner program, you can select a range of cells with the mouse and right click to bring up a copy and paste menu. When you paste data into the PC Link Tuner program, the data is automatically checked and any out-of-range data corrected.

**Chart Operations**

You can rotate the 3D chart display for a better view of a particular region by dragging the mouse while holding both mouse buttons down.

PC Link Tuner is intended to be an open system and uses the Component One Chart 7.0 3D charting control. The adventurous user can experiment with the chart property pages by right clicking on the chart. Almost any chart property can be changed. Click on the Help button for more information. If you corrupt the chart, exit and restart PC Link Tuner.

---

## ***ELECTRONIC THROTTLE CONTROL ISSUES***

All 2008 and later touring models have a throttle control actuator (TCA) that also controls idle air. Throttle position (TPS) refers to the position of the throttle plate in the TCA, not the twist grip sensor. Under warm idle conditions, scan tools will show TPS at about 5% (the value will be higher when the engine is cold). The Twin Tuner subtracts 5% from the actual TPS value. Under warm idle conditions, the Tuner Log software will show zero TPS and the Twin Tuner will operate in the zero TPS and 1000 RPM cell. A similar convention (to subtract 5% from the actual TPS value and report warm idle as zero TPS) is also used by other systems.

---

## APPENDIX – INITIAL SETTINGS

Use the flow chart to select the best initial settings for your application. The Twin Tuner series is appropriate for most Stage 1 (low restriction air filter and free flowing exhaust) and Stage 2 (performance camshafts) applications. For Stage 3 (increased displacement, high compression pistons, and ported heads), we recommend the Twin Tuner II series.

2006 fuel injected Dyna® and all 2007 and later Harley-Davidson® models are equipped with dual narrow-band oxygen sensors and a Delphi® ECM that supports closed loop air/fuel ratio (AFR) control based on feedback from the sensors. After the engine has warmed up, the ECM will maintain the AFR at 14.6 during idle and part throttle cruise. While the ECM is in

closed loop operation, you cannot change the AFR at idle and part throttle cruise by adding fuel with the Twin Tuner. The ECM will correct for any attempt to add fuel in these operating ranges.

If the motorcycle has Stage 1 (low restriction air filter and free flowing exhaust) or Stage 2 (mild performance camshafts) modifications, the ECM can generally make the required fuel changes at idle and part throttle cruise based on closed loop feedback from the oxygen sensors. You can use the Twin Tuner to add fuel at wide open throttle. For more details, please visit our Twin Tuner Tech FAQ at [www.daytona-twintec.com/tech\\_tuner.html](http://www.daytona-twintec.com/tech_tuner.html).

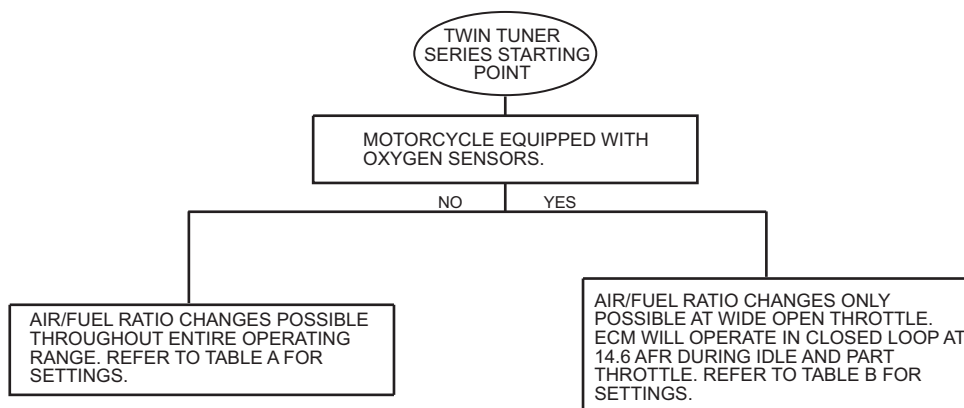

<b>Table A - Twin Tuner Settings</b>			
<b>No Original Equipment Oxygen Sensors</b>			
<b>Parameter</b>	<b>Fuel Trim Operating Range</b>	<b>Stage 1 Mods</b>	<b>Stage 2 Mods</b>
0	Display Off		
1	Idle 750-1250 RPM 0% TPS	0	-5
2	Low cruise 1250-2000 RPM 2.5-50% TPS	5	10
3	High cruise 2000-3750 RPM 2.5-50% TPS	5	10
4	Wide open throttle 1250-2000 RPM 50-100% TPS	10	20
5	Wide open throttle 2000-2750 RPM 50-100% TPS	10	20
6	Wide open throttle 2750-3750 RPM 50-100% TPS	10	20
7	Wide open throttle 3750-4750 RPM 50-100% TPS	10	20
8	Wide open throttle above 4750 RPM 50-100% TPS	10	20
9	Acceleration enrichment	4	5
Notes:			
1. These values will result in a slightly rich initial setup that should be safe for most applications.			
2. Refer to the Twin Tuner Tech FAQ for further tuning suggestions.			

<b>Table B - Twin Tuner Settings</b>			
<b>Original Equipment Oxygen Sensors Installed</b>			
<b>Parameter</b>	<b>Fuel Trim Operating Range</b>	<b>Stage 1 Mods</b>	<b>Stage 2 Mods</b>
0	Display Off		
1	Idle 750-1250 RPM 0% TPS	0	-5
2	Low cruise 1250-2000 RPM 2.5-50% TPS	0	5
3	High cruise 2000-3750 RPM 2.5-50% TPS	0	5
4	Wide open throttle 1250-2000 RPM 50-100% TPS	10	20
5	Wide open throttle 2000-2750 RPM 50-100% TPS	10	20
6	Wide open throttle 2750-3750 RPM 50-100% TPS	10	20
7	Wide open throttle 3750-4750 RPM 50-100% TPS	10	20
8	Wide open throttle above 4750 RPM 50-100% TPS	10	20
9	Acceleration enrichment	4	5
Notes:			
1. These values will result in a slightly rich initial setup that should be safe for most applications.			
2. Refer to the Twin Tuner Tech FAQ for further tuning suggestions.			

---

Use the recommended setup table as a starting point for further tuning. If you have access to a dyno with an exhaust sniffer, refer to the following section for more guidelines. If you do not have access to a dyno, you can still make some adjustments based on the following guidelines:

1. Aftermarket camshafts will generally increase manifold pressure (reduce vacuum) near idle. The Delphi® speed-density control will compensate with excessive fuel resulting in a very rich idle. If the idle still seems rich after using the recommended settings, try further reducing the idle fuel in -5% steps.
  2. If the engine still runs rough or coughs (backfire through the intake) under part throttle cruise conditions, try adding an additional 5-10% fuel in the RPM ranges where problems are noted.
  3. Performance modifications will generally increase the fuel requirement at wide open throttle. If the engine still runs rough or hesitates at wide open throttle, try adding 5-10% fuel in the RPM ranges where problems are noted.
  4. If throttle roll-on response is poor, try using a higher value for acceleration enrichment.
2. Run the engine at part throttle near the middle of the RPM and throttle position ranges for low and high cruise. Trim the fuel so that average AFR readings are near 13.8. If you observe a lean spot where AFR exceeds 14.6, add more fuel. You are always better off with the engine running rich in some areas than coughing in one particular lean spot.
  3. Performance modifications will generally increase the fuel requirement at wide open throttle. However, it is not unusual for some 2-into-1 exhaust systems to have a torque dip at some RPM point where the engine then runs very rich and fuel must be subtracted. Do wide open throttle runs and record AFR values. Target AFR values at wide open throttle are in the 12.8-13.0 range. Make appropriate fuel trim adjustments in each RPM range. High compression engines may exhibit spark knock at wide open throttle. Spark knock can often be eliminated by adding more fuel (AFR in the 12.0-12.5 range) within the affected RPM range.
  4. If throttle roll-on response is poor or a lean transient (high AFR values) is observed, try using a higher value for acceleration enrichment.

If you have access to a load control dyno with an exhaust sniffer, you are in a much better position to make accurate adjustments. Skip steps 1-2 for models with oxygen sensors since the ECM can generally make the required fuel changes at idle and part throttle cruise based on closed loop feedback from the oxygen sensors (refer to following sections for more details about oxygen sensor equipped models).

1. Make sure the engine is fully warmed up and has reached normal operating temperature. Run the engine at idle. Trim the idle fuel, while observing the air/fuel ratio (AFR). Idle AFR should be near 13.5. Very few applications will require adding fuel at idle. Aftermarket camshafts will generally increase manifold pressure (reduce vacuum) near idle. The Delphi® speed-density control will compensate with excessive fuel resulting in a very rich idle. If the idle AFR is still rich after using the recommended settings, try further reducing the idle fuel in -5% steps. If you are using sniffer, obtaining an accurate idle AFR reading may be difficult due to reversion effects. Reversion will result in a false lean AFR reading. If the AFR reading is above 14.6 before fuel trim, but the engine is running reasonably well, you probably have a false lean reading.

### ***Decel Popping***

Decel popping is sometimes encountered with open type exhaust systems without restrictive baffling. The solution involves modifying fuel values at closed throttle above the idle RPM range and requires use of our USB interface and PC Link Tuner software. For more details, please visit our Twin Tuner Tech FAQ at [www.daytona-twintec.com/tech\\_tuner.html](http://www.daytona-twintec.com/tech_tuner.html).