



**CAUTION: CAREFULLY READ INSTRUCTIONS BEFORE PROCEEDING.
NOT LEGAL FOR USE OR SALE ON POLLUTION CONTROLLED VEHICLES.**

OVERVIEW

When used with the Twin Tec TCFI III (or earlier TCFI IID or VRFI D) fuel injection controller, the new dual channel WEGO IIID allows simultaneous front and rear cylinder fuel auto-tuning during actual riding conditions. **The terms TCFI, VRFI, and WEGO are used throughout this document as generic terms and refer to the various TCFI versions, VRFI D version, and WEGO IIID units unless otherwise noted.**

The WEGO IIID system uses low cost Bosch LSU 4.2 5-wire wide-band oxygen sensors. By utilizing miniature surface mount electronics technology, digital signal processing techniques, and a switching power supply for the sensor heater, the WEGO provides the same level of accuracy as lab systems costing thousands of dollars.

WEGO units have dual 0-5 volt analog air/fuel ratio (AFR) outputs that are compatible with Twin Tec fuel injection controllers for closed loop AFR control.

REPLACEMENT SENSORS AND ACCESSORIES

The WEGO uses standard Bosch LSU 4.2 sensors used on a VW production application (Bosch P/N 0 258 007 057/058 or VW P/N 021 906 262B). The proprietary VW connector is replaced with a smaller Deutsch DT-04-6P. We offer replacement sensors with the Deutsch connector installed.

If you are testing multiple engines, we also offer additional 18 x 1.5 mm weld nuts for sensor mounting and 18 x 1.5mm hex socket plugs that screw into the weld nuts and allow removing sensors after tuning.

INSTALLATION

1. Turn off the ignition switch and disconnect the battery ground cable before proceeding.
2. In general, the sensors should be mounted 2-8 inches from the head flange. Available clearance will usually dictate the optimum location. When choosing a mounting location, allow several inches clearance for the sensor wire harness. The wire

harness must exit straight out from the sensor. Do not loop the harness back onto the sensor body.

3. **2006 and later models with original equipment oxygen sensors (all others skip ahead to step 4).** You can use the original equipment (OE) oxygen sensor mounting bosses. Remove the OE sensors. You do not have to remove any of the OE wiring, just tape up the mating connectors. Do not install the new Bosch sensors until after the free air calibration procedure described in the following section. Always use an anti-seize lubricant such as Permatex 133A on the sensor threads. Softail® models may require removal of the seat post/coil bracket for clearance during installation of the rear sensor. Skip ahead to step 5.
4. 18 x 1.5 mm weld nuts must be welded onto the exhaust pipes. After welding, run an 18 x 1.5 mm tap through the threads. Failure to clean the threads may result in sensor damage. Note that most automotive muffler shops are familiar with oxygen sensor weld nut installation on custom pipes. Do not install the sensors until after the free air calibration procedure described in the following section. Always use an anti-seize lubricant such as Permatex 133A on the sensor threads.

Figure 1 – Typical Sensor Installation



5. Install the WEGO unit. The WEGO is fully sealed and can be located near the TCFI/VRFI unit. You can secure the WEGO with Velcro tape strips or a few tie wraps on the wire harness.
6. Connect the Bosch sensors to the 6 pin mating connectors on the WEGO wire harness. The longer cable (with yellow band) is for sensor 1 (front). For additional protection and improved cosmetics, use Techflex 1-1/4" Black Flexo Clean Cut FR expandable sleeving over the connectors (available from www.wirecare.com).
7. Refer to Figure 2. Connect the two black WEGO wires to frame ground using the supplied ring terminal. Try to use an existing wire harness ground location. **Do not extend the WEGO ground wires or ground the WEGO to the battery minus terminal or to the engine.**
8. Connect the red WEGO wire to switched +12 volt power. You can usually find switched +12V power at an accessory fuse on the fuse block. You can use the supplied fuse tap and 3/16" female crimp terminal for this purpose.
9. The WEGO parts bag includes white and blue extension wires. Each has a Packard Weather Pack connector on one end and a small female Micro-Pack terminal on the other end. These extension wires are used to connect the WEGO to the TCFI/VRFI as shown in Figure 2. The female Micro-Pack terminals are installed in the OE Delphi connector that mates with the TCFI/VRFI. Carefully open the Delphi strain relief and remove the clear plastic retainer. Pull out the blue seals at pins 8 and 23. **2006 and later models with original equipment oxygen sensors: remove and tape up the existing wires at these pins.** Install the female Micro-Pack terminals. Pin numbers are marked on the strain relief.
10. Reconnect the battery ground cable.

Figure 2 - WEGO Hookup

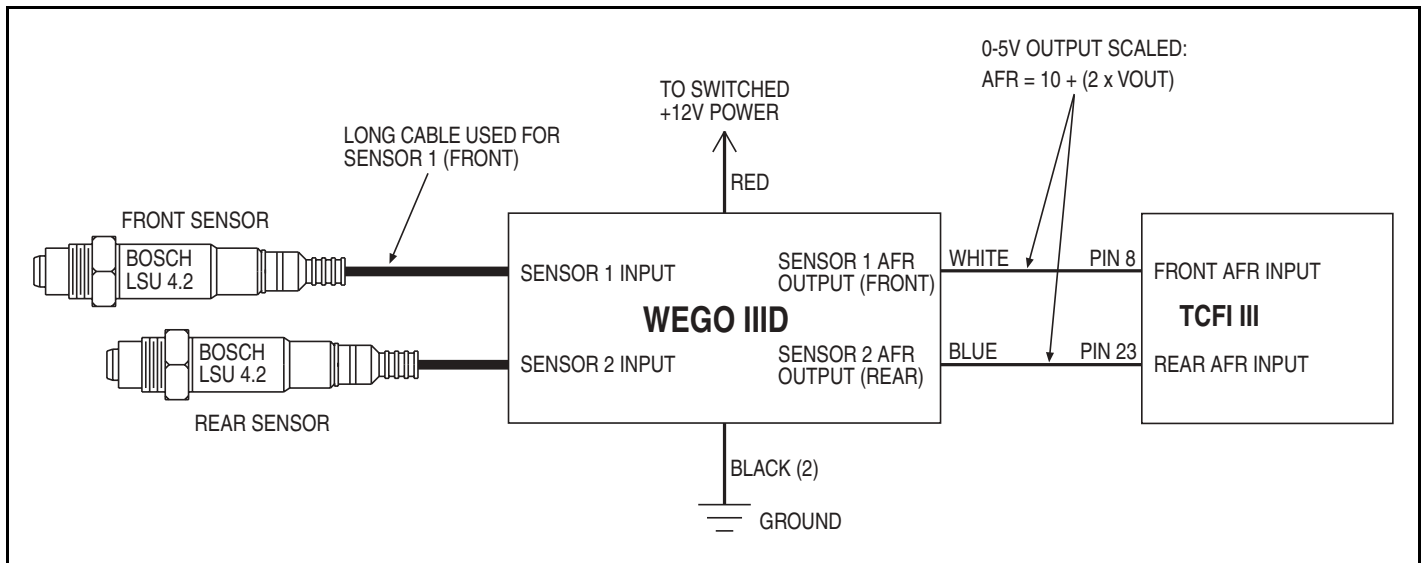

OPERATION

For more information about wide-band oxygen sensors including the Bosch LSU 4.2, we suggest that you visit the Tech FAQ on our website at www.daytona-sensors.com.

The WEGO has red status LEDs for each channel. When power is turned on, the LEDs blink at a slow rate until the corresponding sensor has reached normal operating temperature.

After installation, the WEGO system requires free air calibration. This should be done with the sensors dangling in free air. The environment must be free of hydrocarbon vapors. We suggest that you perform the free air calibration outdoors. Turn the free air calibration trimpots on the WEGO full counterclockwise. Turn on power and wait for 60 seconds so the system can fully stabilize. Then slowly turn each free air calibration trimpot clockwise until the corresponding LED starts flashing at a rapid rate. Try to set each trimpot at the point where its LED just starts to flash.

The free air calibration procedure should be performed at reasonable intervals (every 250-500 hours) or whenever a sensor is replaced. If you cannot get an LED to rapidly flash when its trimpot is turned full clockwise, you either have a damaged sensor or very high hydrocarbon levels in your environment.

If both LEDs keep blinking at the slow rate, you may have a low battery voltage condition. Try connecting a battery charger.

Figure 3 - WEGO Unit



The WEGO includes internal diagnostics for abnormal battery voltage (less than 11 volts or greater than 16.5 volts), sensor open circuit, and sensor short circuit conditions. A fault condition causes the status LEDs to blink at the slow rate.

CAUTION: Racing gasoline containing lead will quickly degrade the sensors. Under these conditions, expected sensor life is less than 10 hours. There is no warranty on sensors.

EXHAUST CONSIDERATIONS

The WEGO system may give inaccurate results in certain situations:

Excessive exhaust back pressure. Wide-band sensors are affected by back pressure. Excessive back pressure causes exaggerated AFR indications under

rich and lean conditions, but has little effect at 14.7 AFR (stoichiometric). Motorcycle exhaust systems are relatively free flowing and problems with exhaust back pressure are not likely.

Exhaust reversion. Reversion is the term for a negative pressure wave that can suck ambient air back into the exhaust and cause an erroneous lean AFR indication. Open drag pipes suffer from reversion effects and auto-tuning may not be possible at idle or part throttle. Fuel tables for these cells will have to be tuned manually. Reversion effects will also occur with certain exhausts used on “bagger” style motorcycles, where two pipes split off near the rear cylinder. At part throttle, air is actually sucked into the left tailpipe. The only solution is to install a true dual type performance exhaust. Reversion effects will be most noticeable at idle, part throttle low RPM cruise, and decel.

WARNING: If you can insert a broomstick through the mufflers, you have the equivalent of open drag pipes and the WEGO sensors will not read accurate AFR values.

You can reduce reversion effects in open drag pipes and mufflers without restrictive baffles with the modification shown in Figure 4.

Figure 4 – Exhaust Mod to Reduce Reversion



Use washers with an OD that is 2/3 to 3/4 the ID of the pipe (for example, 1-1/2" OD washers are suitable for pipes with an ID of 2" to 2.25"). Weld ¼-20 socket head cap screws to the washers as shown. Drill holes at the bottom of the pipes about 2" from the end and use decorative acorn nuts to secure the washer assemblies. We suggest that you use stainless steel hardware.

The washers will reflect positive pressure waves that will cancel out the negative pressure waves

reflecting from the end of the pipes. You can turn the washers just like throttle blades to provide more or less restriction. Dyno tests will show a significant increase in midrange torque and a small drop in top end horsepower as the restriction is increased.

Excessive scavenging. Tuned exhausts in combination with a high overlap camshaft profile can pull unburned air and fuel mixture through the cylinder into the exhaust and cause an erroneous rich AFR indication. Some aftermarket 2-into-1 systems, such as the Thunderheader appear to suffer from this problem, whereas others such as the Vance & Hines Pro Pipe and White Brothers E-series seem less affected.

Misfiring. If the AFR is so rich that the engine misfires, high levels of oxygen will remain in the exhaust gas and result in an erroneous lean indication.

ENGINE TUNING GUIDELINES

Higher AFR values correspond to a leaner (less fuel) condition. The practical operating range for most engines using gasoline fuel is from approximately 11.5 to 14.7 AFR. Combustion of a stoichiometric mixture (exactly enough air to burn all the fuel) results in 14.7 AFR indication. Automotive engines with catalytic converters operate near 14.7 AFR during cruise and idle. Air-cooled motorcycle race engines usually

require a richer mixture to limit cylinder head temperature and prevent detonation. The following table lists reasonable AFR values for race engines without emission controls.

Operating Mode	Recommended AFR
Cold Start (first 30 sec)	11.5-12.5
Idle	12.8-13.5
Part Throttle Cruise	13.0-14.0
Wide Open Throttle	12.5-12.8 (values down to 11.5 may be used to reduce detonation)

TROUBLESHOOTING FLOWCHART

Follow the troubleshooting flowchart shown below. Experience has shown that most units returned for warranty are OK and another problem, such as user error, a degraded sensor, or bad power connections is later identified.

Troubleshooting Flowchart

